

# Dynamic Response Analysis of Start-up Transient in Air Conditioning System



รองศาสตราจารย์ ดร.ประกอบ สุวัฒน์นารณ<sup>1</sup> และ สุรสิทธิ์ พลพันธ์<sup>2</sup>

*1รองคณบดี คณะวิศวกรรมศาสตร์ มหาวิทยาลัยเกษตรศาสตร์ กรุงเทพฯ*

*E-mail: fengpsw@ku.ac.th โทรศัพท์: 02-7970999 ต่อ 1803 โทรสาร: 02-5794576*

*2นิสิตปริญญาเอก ภาควิชาวิศวกรรมเครื่องกล คณะวิศวกรรมศาสตร์ มหาวิทยาลัยเกษตรศาสตร์ กรุงเทพฯ*

## Abstract

Dynamic models of the heating, ventilation and air-conditioning (HVAC) systems in a temperature controlled room are very useful for controller design, commissioning, and fault detection and diagnosis. A transient model is a set of time differential equations in mass, energy and momentum balances. These transient equations contain parameter values for validation. The parameter such as thermal capacitances of the room chamber, heat transfer coefficient of room panel, heat transfer coefficient of evaporator are difficult to determine because they are related to unsteady condition and have to be considered to account for room energy storage. Many researchers have been studied the transient model for HVAC

system by setting an assumption that there parameters are already known. None of them has been investigated into the parameter identification. This research work focused into the parameter identification technique to determine the thermal capacitances of the room chamber, heat transfer coefficient of room panel, and heat transfer coefficient of evaporator. The transient model of a refrigeration unit for an air-conditioned room was analyzed. Block diagram technique along with computer simulation technique were applied for the task. Experimental tests were setup to validate this model.

**Keywords:** modeling, transient, HVAC, refrigeration, parameter identification.

## 1. Introduction

It is well known that the dynamic performance of a Heating, Ventilation and Air Conditioning (HVAC) system has great impact on power and energy consumption, as well as on indoor air quality. In order to study the system performance at the design stage, it is necessary to obtain approximate mathematical models for system components. In addition, efficient control strategies play an essential role in developing improved energy control systems for buildings. The most important criteria for designing HVAC plants are energy efficiency and indoor climate conditions [1]. An adequate combination of these two criteria demand gives the proper control of the plant. The design of successful controllers for HVAC systems primarily depends on the availability of good dynamic models of the systems and mathematical equations that describe its behavior. The complexity of an HVAC system with distributed parameters, interactions, and multivariable makes it extremely difficult to obtain an exact mathematical model to improve control quality.

In theory, the complete operation cycle of a refrigeration system can be characterized by two major time-regimes, namely transient and steady state [2]. In the latter, the system input/output parameters are constant over time; transient operation is then, by default, the non-steady state. Typically, this is the case when the system is started-up and is approaching steady state, or when it is shutdown from a steady state, or when it is disturbed from its steady state. This disturbance could be caused by either external changes in conditions (such as load, ambient temperatures etc.) or by feedback control. Dynamic models of the heating, ventilation and air-conditioning (HVAC) systems in the building are very useful for

controller design, commissioning, and fault detection and diagnosis. Different applications have different requirements on the models and different modeling approaches can be applied. In either case, the system attempts to move from one equilibrium state to another. Transient modeling is the predictive analysis of the system's operation during such conditions.

Man-Hoe Kim and Clark W. Bullard [3] present experimental results on the shut-down and start-up characteristics of a residential split system R410A air-conditioner with a capillary tube. During shut-down, the transient characteristics are evaluated by measuring the high and low side pressures and temperatures of the system. The dynamic behavior of the system after start-up is also investigated,

Steve Pfister [4] presents a method for predicting the cooling performance of vapor compression refrigeration systems during transient and various ambient conditions based on established steady-state performance. The performance of existing refrigeration systems and components were characterized during cooling from initial ambient temperature and steady state operation. An empirical relation between the measured compressor COP and Carnot COP during initial pull down and steady state operation were derived. Compressor COP calculations based on condensing temperature and evaporating temperature.

B. Yu and AHC Van Paassen [5] applied bond graph to create a dynamic model of an air-conditioned room. Bond graph technique was discussed in terms of advantage and disadvantage. It is shown that combination with two approaches to realize complicated models of building HVAC system for the application of model-based fault detection and diagnosis is a good solution.

The parameter values are very important for validate the model. Some parameter such as mass, area, specific heat, etc are not difficult to determine because they are related to steady state condition. But some parameter such as thermal capacitances of the room chamber, heat transfer coefficient of room panel, heat transfer coefficient of evaporator, etc are difficult to determine because they are related to transient condition. There parameters have to be considered to account for room energy storage. Many researchers have been studied the transient model for HVAC system by setting an assumption that these parameters are already known [6-8]. None of them has been investigated into the parameter identification. In this work, we focus into the parameter identification technique to determine the thermal capacitances of the room chamber, heat transfer coefficient of room panel, and heat transfer coefficient of evaporator.

## 2. System modeling

The major components considered in the system model are: an air-conditioned room and refrigeration unit, which consists of a compressor, evaporator, condenser, expansion device as shown in Fig. 1.

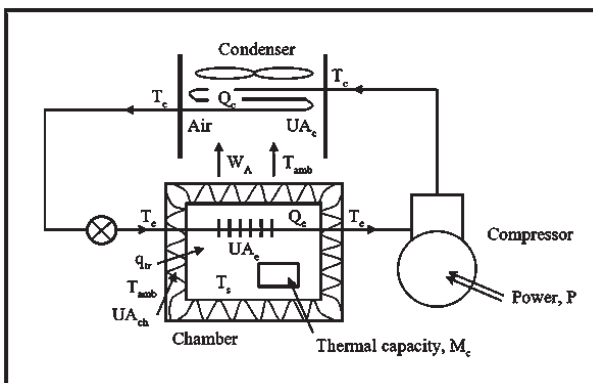

Fig 1: Schematic diagram of HVAC system [2]

The refrigeration system is to maintain a low temperature in the chamber. The evaporator that is located in the chamber removes the heat from the space that is conducted in through the walls and also that heat removed from the thermal capacity of the contents of the room chamber. At evaporator unit, the heat transfer from the evaporator to the cooling space can be expressed by

$$q_e = UA_e(T_s - T_e) \quad (1)$$

where

$q_e$  = heat transfer from the evaporator to the cooling space in watt

$U$  = coefficient of heat transfer in watt/m<sup>2</sup>

$A_e$  = heat exchange area of the evaporator in m<sup>2</sup>

$T_s$  = temperature of cooling space in deg C

$T_e$  = temperature of evaporator in deg C

At the room chamber, assume that the heat transfer between the space air temperature  $T_s$  and the object is good and that the internal conduction is high so that the temperature of these objects is the same as  $T_s$ . The energy balance within the space is:

$$q_{tr} = UA_{ch}(T_{amb} - T_s) \quad (2)$$

where

$q_{tr}$  = heat transfer from the ambient to the room chamber in watt

$U$  = coefficient of heat transfer in watt/m<sup>2</sup>

$A_{ch}$  = heat exchange area of the room chamber in m<sup>2</sup>

$T_{amb}$  = temperature of ambient air in deg C

$T_s$  = temperature of cooling space in deg C

In the pull-down of temperature of the refrigerated space from a warm condition, the object in the space have a thermal capacity that is a summation of products of the masses and the specific heats of the individual contents of the space. Heat transfer from the ambient to the room chamber  $q_{tr}$  is no longer equal to heat transfer from the evaporator to the cooling space  $q_e$  because of the transient effect  $M_c \frac{dT_s}{dt}$ . This phenomena can be expressed by

$$q_{tr} = q_e + M_c \frac{dT_s}{dt} \quad (3)$$

where

$q_{tr}$  = heat transfer from the ambient to the room chamber in watt

$q_e$  = heat transfer from the evaporator to the cooling space in watt

$M_c$  = product of mass and specific heat

$T_s$  = temperature of cooling space in deg C

Because of their special relationship to differential equations, Laplace transforms are a powerful tool in analyzing the behavior of dynamic processes. The Laplace transform has been applied to all above equations. To facilitate the procedure, the equations have been arranged in a block diagram formats. Block diagram represents either processes that instantaneous or time dependent. The summing points are algebraic additions of two or more inputs to yield and output. It can be seen that the system contains two inputs ( $T_e$  temperature of evaporator in deg C and  $T_{amb}$  temperature of ambient air in deg C), one output ( $T_s$  temperature of cooling space in deg C).

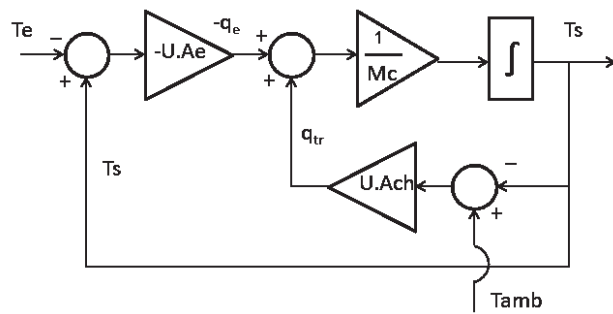

Fig 2: Block diagram of HVAC system

The HVAC model is MISO (multiple input and single output). In order to proceed the parameter identification, one input ( $T_{amb}$ ) must be treated as constant value. This assumption can be made because the dynamic input can be separately analyzed. Consequently, the system becomes SISO (single input  $T_e$  and single output  $T_s$ ). The system contains two feedback loops and must be reduced down. The internal loop is shown in Fig 2. The transfer function relating  $q_e$  to  $T_s$  is called the closed loop transfer function. This transfer function relates the closed loop system dynamics to the dynamics of the feedforward elements and feedback elements.

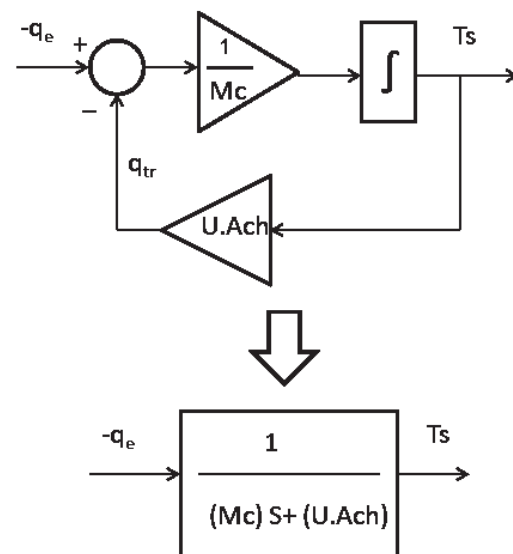

Fig 3: Feedback elements with integrator

It is important to note that blocks can be connected in series only if the output of one block is not affected by the next following block. If there are any loading effects between the components, it is necessary to combine these components into a single block. Any number of cascade blocks representing nonloading components can be replaced by a single block, the transfer function of which is simply the product of the individual transfer functions. A complicated block diagram involving many feedback loops can be simplified by a rearrangement, using rules of block diagram algebra (Fig 3). Simplification of the block diagram by rearrangements and substitutions considerably reduced the labor needed for subsequent mathematical analysis. However, it should be noted as the block diagram is simplified the transfer functions in new block become more complex because now poles and new zeros are generated. The block diagram reduction is shown in Fig 4.

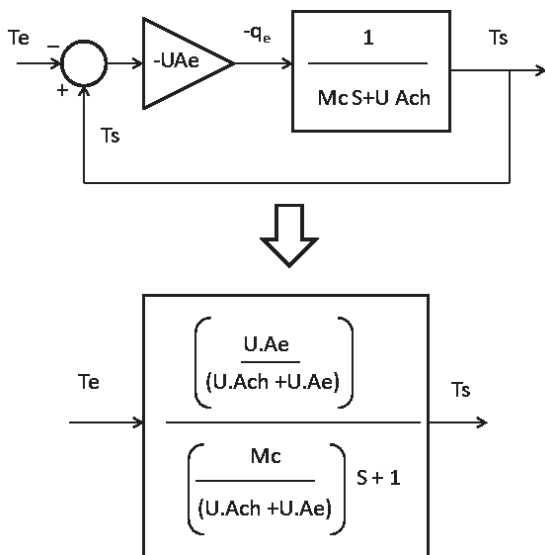

Fig 4: Block diagram reduction

Physically, the input-output relationship of the HVAC system is given by

$$\frac{T_s(s)}{T_e(s)} = \frac{\left\{ \frac{UA_e}{UA_{ch} + UA_e} \right\}}{\left\{ \frac{M_c}{UA_{ch} + UA_e} \right\} s + 1} \quad (4)$$

$$\frac{T_s(s)}{T_e(s)} = \frac{K}{\tau s + 1} \quad (5)$$

where

$$K = \text{system gain} = \frac{UA_e}{UA_{ch} + UA_e}$$

$$\tau = \text{time constant} = \frac{M_c}{UA_{ch} + UA_e}$$

The system can be classified as first-order system with system gain  $K$  and time constant  $\tau$ . The time response of the system consists of two parts: the transient and the steady-state response. By transient response, we mean that which goes from the initial state to the final state. By steady-state response, we mean the manner in which the system output behaves as  $t$  approaches infinity. The step function is used as the test signal in this research works. With the test signals, mathematical and experimental analyses can be carried out easily since the step signals are very simple function of time.

Since the Laplace transform of the unit-step function is  $1/s$ , substituting  $T_e(s) = 1/s$  into equation x, we obtain

$$T_s(s) = \left\{ \frac{1}{s} \right\} \left\{ \frac{K}{\tau s + 1} \right\} \quad (6)$$

$$T_s(s) = \frac{\left( \frac{K}{\tau} \right)}{(s+0) \left( s + \frac{1}{\tau} \right)} \quad (7)$$

Expanding  $T_e(s)$  into partial fractions gives

$$T_s(s) = \frac{a_1}{(s+0)} + \frac{a_2}{\left(s+\frac{1}{\tau}\right)} \quad (8)$$

where

$$a_1 = \left[ \frac{\left(\frac{K}{\tau}\right)}{\left(s+0\right)\left(s+\frac{1}{\tau}\right)} (s+0) \right]_{s=0} = K$$

$$a_2 = \left[ \frac{\left(\frac{K}{\tau}\right)}{\left(s+0\right)\left(s+\frac{1}{\tau}\right)} \left(s+\frac{1}{\tau}\right) \right]_{s=-\frac{1}{\tau}} = -K$$

$$T_s(s) = \frac{K}{(s+0)} + \frac{-K}{\left(s+\frac{1}{\tau}\right)} \quad (9)$$

Taking the inverse Laplace transform, we obtain

$$T_s(t) = K \left\{ 1 - e^{-\left(\frac{t}{\tau}\right)} \right\} \text{ for } t \geq 0 \quad (10)$$

This equation state that initially the output  $T_s(t)$  is zero or initial state and finally it becomes K values when the transient state is die out. One important characteristic of such an exponential response curve  $T_s(t)$  is that at  $t = \tau$  the value of  $T_s(t)$  is 0.632 of K value (steady state value), or the response  $T_s(t)$  has reached 63.2% of its total change. This can be seen by substituting  $t = \tau$  in  $T_s(t)$ , that is

$$T_s(t) = K \left\{ 1 - e^{-1} \right\} = 0.632 K \quad (11)$$

Note that the smaller the time constant  $\tau$ , the faster the system response. Another important characteristic of the exponential response curve is that the slope of the tangent line at  $t = 0$  is

$$\frac{dT_s(t)}{dt} = \frac{K}{T} e^{-\left(\frac{t}{\tau}\right)} = \frac{K}{T} \quad (12)$$

The exponential response curve  $T_s(t)$  is shown in one time constant with  $K = 1$ , the exponential response curve has gone from 0 to 63.2% of the final value. In two time constant, the response reaches 86.5% of the final value. At  $t = 3T, 4T,$  and  $5T$ , the response reaches 95%, 98.2%, and 99.3%, respectively, of the final value. Thus, for  $\geq 4\tau$ , the response remains within 2% of the final value (Fig 5).

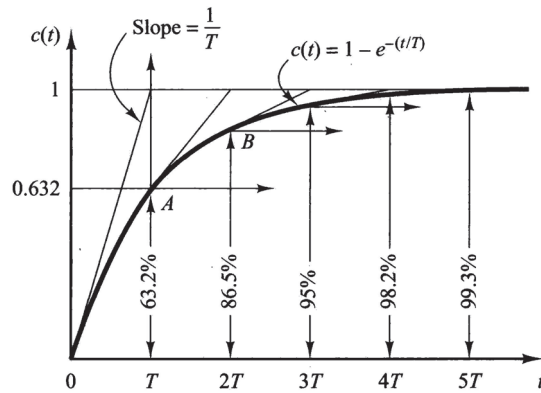

Fig 5: Transient response of first-order system [9]

### 3. Experimental test

According to the equation (1) - (3), there are three unknown parameters ( $UA_e, UA_{ch}$  and  $M_c$ ), the experiment was set up to identify these values. The test rooms was divided into 2 rooms with equal dimension of 2.35 m width x 2.8 m depth x 2.65 m height, one for evaporator unit and another for condensing unit. The walls of both rooms made from brick. Ambient temperature in the condensing unit test room was controlled by supplied cooled air into the room from another air conditioner.

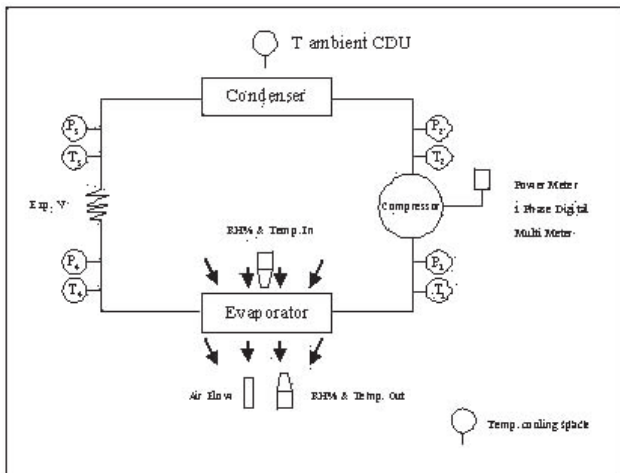

Fig 6: Diagram of experimental apparatus

Data measured by all sensors has been transferred to a data logger system. Split type air conditioner used in the study is wall type, 12,300 BTU/hr cooling capacity, using R-22 as refrigerant. A Schematic of experimental split type air conditioning system is shown in Fig 6. The sensors include temperature, pressure, humidity, air velocity, and power meter. All sensors have been calibrated in the proper operating ranges and prepared for the full scale analysis in the future work of this project. In this report, only temperature sensors were used to collect the data because the objective is focus at parameter identification.

Because the ambient temperature in the condensing unit test room must be controlled, the digital temperature controller was installed in the condensing units test room to control the operation of the air conditioner which supplies the cold air into the condensing unit test room. Ambient temperature was set to 35 deg C while the cooling space temperature was set to 25 deg C. Pressure at suction side of the refrigeration system was adjusted to the designed pressure value of 70 psig so that the evaporating temperature was equal to 5 deg C.

To run the test facilities (Fig 7 and Fig 8), firstly, the ambient temperature in condensing unit test room was set to 35 deg C by setting at digital temperature controller and run the test air conditioner until the steady state condition was reached. After the ambient temperature in condensing unit test room was controlled, the refrigeration for evaporating room was started.

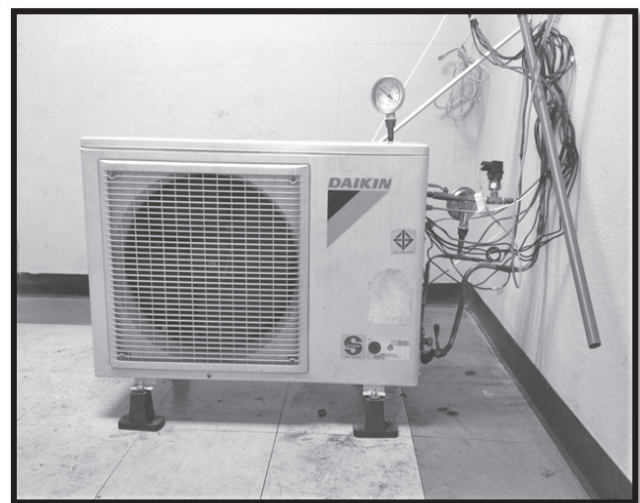
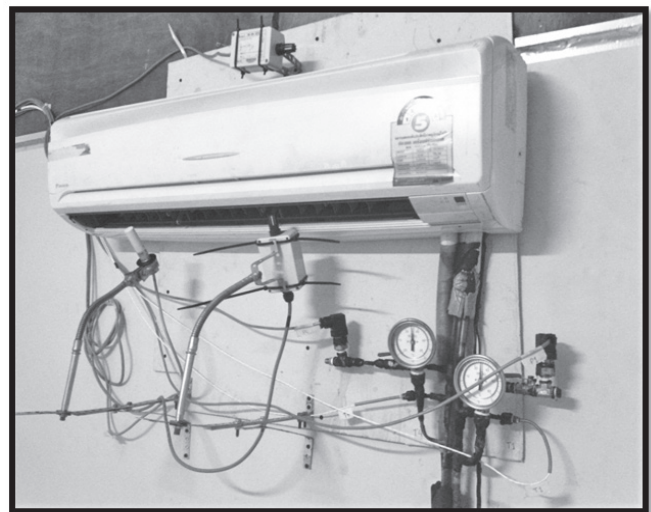

Fig 7: Measurement devices set up

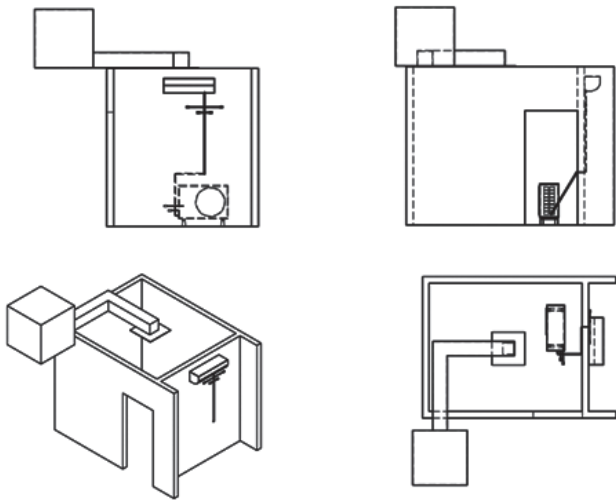

Fig 8: Experimental room layout

The split type air conditioner has a cooling capacity ( $q_e$ ) of 12,300 BTU/hr (3,605 watt of thermal power). By substituting in equation (1) with  $T_s = 25$  deg C,  $T_e = 5$  deg C and  $q_e = 3,605$  watt, UAe value is obtained as 180.25 Watt / deg C. To determine the value of parameters UAch and  $M_c$ , unit-step response of first-order system is applied by comparing the experimental data with the mathematical model results from MATLAB/Simulink simulation. The conditions of the simulation are:

- (1) Evaporating temperature ( $T_e$ ) and ambient temperature ( $T_{amb}$ ) are inputs while cooling space temperature ( $T_s$ ) is output of the system.
- (2)  $T_e$  is defined as step input from 0 to 5°C and  $T_{amb}$  as constant value of 35°C.
- (3) Initial cooling space temperature ( $T_s$ ) is 31°C and the set point of is 25°C.

By using the curve fitting simulation, give  $UA_e = 180.25$  watt/deg C,  $UA_{ch}$  and  $M_c$  were varied until the results from simulation reveal good agreement with the experimental results. By using the principle of time constant, it was found that the values of  $UA_{ch}$  and  $M_c$  were been 400 watt / deg C and

380,000 J/deg C, respectively. It can be seen that oscillation occurred in the curve of experimental result. It was due to the on/off control operation of split type air conditioner.

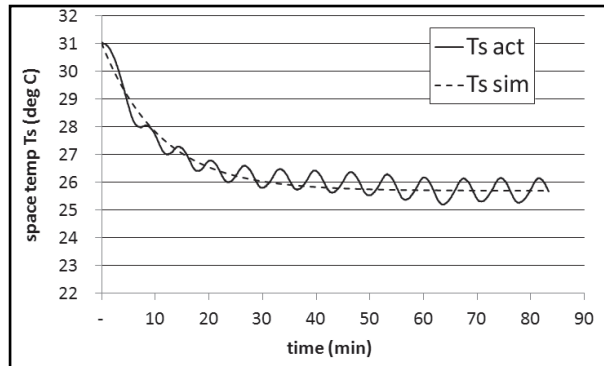

Fig 9: Comparison of space room temperature between simulation and experiment

### Create the dynamic models to predict cooling space temperature

Mathematical models have been established in MATLAB/Simulink to predict cooling space temperature in case of some conditions varied. Step input  $T_e$  had been changed to constant, as well as, constant  $T_{amb}$  had been changed to step input corresponding to  $T_s$  as the output.

### Prediction of cooling space temperature ( $T_s$ ) under variation of ambient temperature ( $T_{amb}$ )

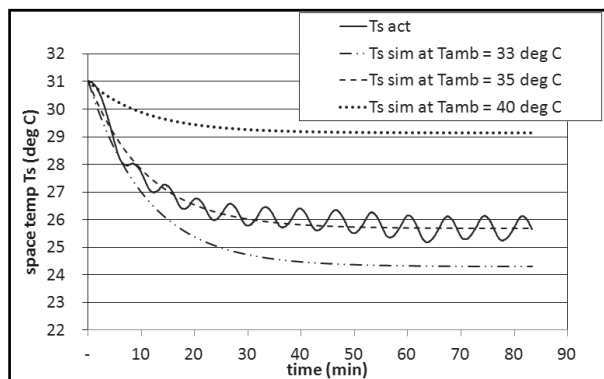

Fig 10 : Predicted cooling space temperature ( $T_s$ ) curves under various ambient temperatures



A simulation was performed under various ambient temperatures of 33, 35, 40 and 45°C. The results are illustrated in Fig 10. When ambient temperature increases, cooling space temperature increases. This is because the air conditioner cannot transfer heat to the outside with the proper rate as it should so that cooling space temperature is likely to increase until the equilibrium where cooling space temperature become constant is achieved.

### Prediction of cooling space temperature ( $T_s$ ) as the size of air conditioner is changed

Prediction of cooling space temperature with regard to various cooling capacities of an air conditioner which causes  $UA_e$  value in the model varies was performed under ambient temperature of 35°C.

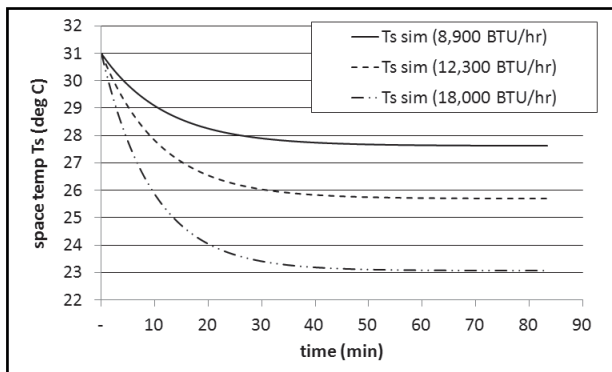
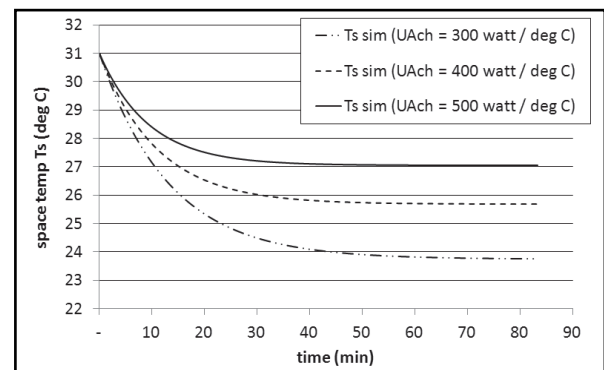

**Fig 11:** Predicted cooling space temperature ( $T_e$ ) curves under various cooling capacities

To predict cooling space temperature, simulation was performed by varying  $UA_e$  value and keeping  $UA_{ch}$  and  $M_c$  value constant. For the capacity of 8,900 and 18,000 BTU/hr, the corresponding  $UA_e$  are 134.0 and 263.8 watt/deg C, respectively. The

results are illustrated in Fig 11. When the cooling capacity of an air conditioner decreases, cooling space temperature increases. Because air conditioner cannot exchange the heat with the space to be cooled and transfer it with properly rate to the outside, causing the rise in cooling space temperature.

### Prediction of cooling space temperature ( $T_s$ ) as $UA_{ch}$ is changed



**Fig 12:** Predicted cooling space temperature ( $T_s$ ) curves under various  $UA_{ch}$  ( $T_{amb} = 35^\circ\text{C}$ )

When the insulation is added to the walls the wall thickness will be increased which leads to the decrease of  $UA_{ch}$  value. In this study,  $UA_{ch}$  were defined as 300 and 500 watt/ deg C. Predicted cooling space temperature curves under various  $UA_{ch}$  are illustrated in Fig 12. In case of insulation is added to the wall, heat transfer rate through the wall is decreased from outside into inside. Hence, cooling space temperature decreases.

**Prediction of cooling space temperature ( $T_s$ ) as  $M_c$  is changed**

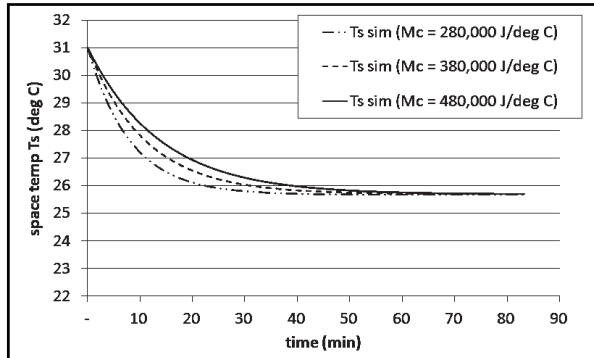

**Fig 13:** Predicted cooling space temperature ( $T_s$ ) curves under various  $M_c$  ( $T_{amb} = 35^\circ\text{C}$ )

Product of mass and specific heat of contents inside the room will be changed with cooling load changes. For example, when more people are living in the room, this increases the product of mass and specific heat of contents. The specified  $M_c$  values had been varied from 280,000 to 480,000 J/deg C. Fig 13 shows predicted cooling space temperature curves under various  $M_c$  values. Simulation results show that when product of mass and specific heat of contents inside the room increase, it will take longer time for the operation of an air conditioner in order to lower the cooling space temperature to settle in equilibrium.

**4. Conclusions**

In typical HVAC transient model, there are some unknown parameters needed to identified such as the thermal capacitances of the room chamber, heat transfer coefficient of room panel, and heat transfer coefficient of evaporator.

Parameter identification can be performed by mathematical model simulation technique along with actual step input time response.

The transfer function technique can be used to determine the unknown parameters from experimental results.

Transient model of HVAC system has significant impact on the system performance.

Transient simulation result shows that the heat transfer coefficient of room panel and heat transfer coefficient of evaporator influence the rise time and the steady state condition of cooling space temperature.

Even though the thermal capacitance of the room chamber has no influence on the steady state condition, but has significant impact on the system time delay.

**5. Acknowledgements**

This study was sponsored by Research and Development of Refrigeration and Air conditioning Engineering, Kasetsart University, Bangkok, Thailand.

## 6. References

- [1] Edward G. Pita (2002), Air Conditioning Principles and Systems: An Energy Approach, Fourth Edition.
- [2] W.F. Stoecker (1989). Design of Thermal Systems, Third Edition, McGraw-Hill.
- [3] M.H.Kim and C.W.Bullard (2000), Dynamic Characteristics of a R-410A Split Air Conditioning System, Purdue University, Purdue e-Pubs, International Refrigeration and Air Conditioning Conference.
- [4] Steve Pfister (2004), Transient Modeling of Vapor Compression Refrigeration Systems Using Measured Compressor COP, Purdue University, Purdue e-Pubs, International Refrigeration and Air Conditioning Conference.
- [5] B.Yu and A.H.C. van Paassen (2004), Simulink and bond graph modeling of an air-conditioned room, Science Direct, Simulation Modeling Practice and Theory 12, p 61-76
- [6] Michael Anderson et al (2007), An experimental system for advanced heating, ventilating and air conditioning (HVAC) control, Science Direct, Energy and Building 39, p 136-147
- [7] P. Techarungpaisan et al, Modeling of a split type air conditioner with integrated water heater (2007), Science Direct, Energy Conversion and Management 48, 1222-1237
- [8] Yi-guang Chen and Xian-min Guo (2009), Dynamic defrosting characteristics of air source heat pump and effects of outdoor air parameters on defrost cycle performance, Applied Thermal Engineering 29, p 2701-2707
- [9] Katsuhiko Ogata (2002). Modern Control Engineering, Fourth Edition, Prentice Hall.